

C2C CUBE 111

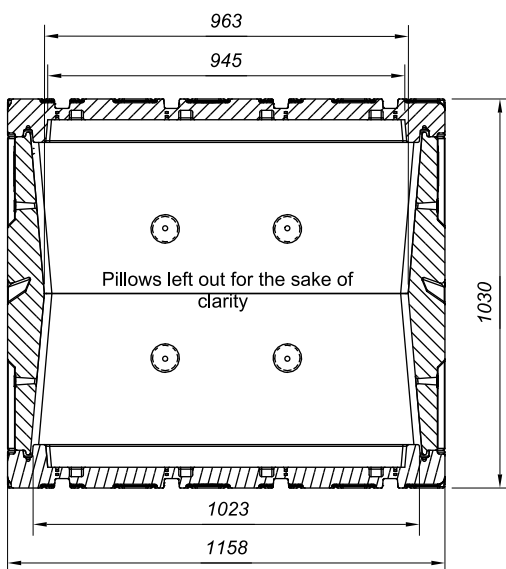

C2C Cube

Connecting cleanrooms.

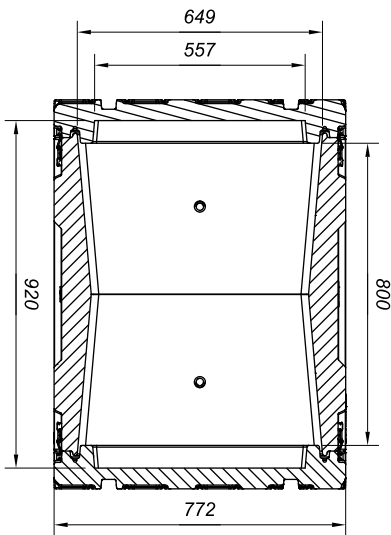

Cube specifications

Item number	4022.474.9990
Materials used	PELD, Fluorelastomer, Stainless steel
	<ul style="list-style-type: none"> • ISO class 5 • Tested and released according to ISTA & GID • Equipped with RFID tags • Cleanable label surface • Fastening holes inside • Hoisting belts and straps inside CE certified • Pillows of cleanroom fabric filled with LRPU foam • This model has 3 parts (bottom, sleeve, lid)

External dimensions 1158 x 772 x 1030 mm

Internal dimensions 945 x 557 x 920 mm

Net weight 68 kg

Content specifications

Max sensitivity	15 G on product
Target size product	800 x 500 x 500 mm
Max part size	910 x 520 x 570 mm
Pillow size	970 x 580 x 195 mm
Max part weight	100 kg*

Transport packaging

	<ul style="list-style-type: none"> • Cube packed in double antistatic LDPE bags • Hoisting belts around the cube • Packed cube inside corrugated carton • Corrugated carton on a pallet
Total weight	80 kg
Transport size	1200 x 800 x 1050 mm**

*Higher weights possible at different G **Without pallet